



# C2947M-B (3/08) C10CH Series Camera Quick Start Guide

This quick start guide describes how to install and configure the C10CH Series camera in most applications. It contains a representation of the setup menus to help you locate and change specific settings.

Refer to the enclosed CD for the following documentation:

- Installation/Operation manual: C2946M
- Quick Start Guide: C2947M
- Important Safety Instructions: SAFETY.PDF

## MODELS

C10CH-6 1/3-inch ultra high resolution color, CCD camera, 24 VAC or 12 VDC, NTSC format

C10CH-6X 1/3-inch ultra high resolution color, CCD camera, 24 VAC or 12 VDC, PAL format

C10CH-7X 1/3-inch ultra high resolution color, CCD camera, 230 VAC, PAL format

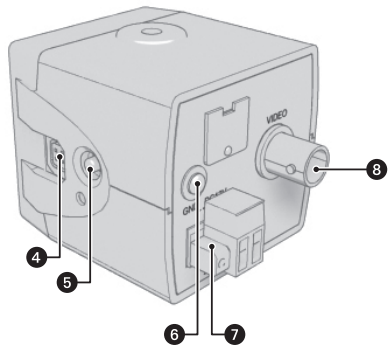
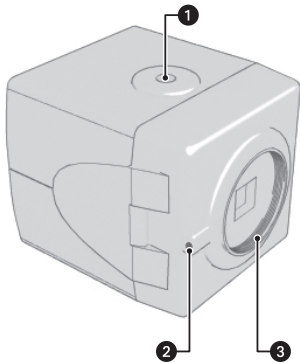

- ❶ Camera Mount
- ❷ Back Focus Locking Screw
- ❸ Lens Mount
- ❹ Auto Iris Lens Connector

- ❺ Setup Button
- ❻ Ground Screw
- ❼ Power Terminal Block
- ❽ Video Output Connector

# SETUP MENUS

The camera default settings are set at the factory to operate in most applications and lighting conditions, and normally require no adjustments. Sometimes, however, adjustments may be necessary.

Use the setup menus to customize the camera settings for your application as needed. Refer to the Installation/Operation manual for complete instructions and explanations of camera settings.

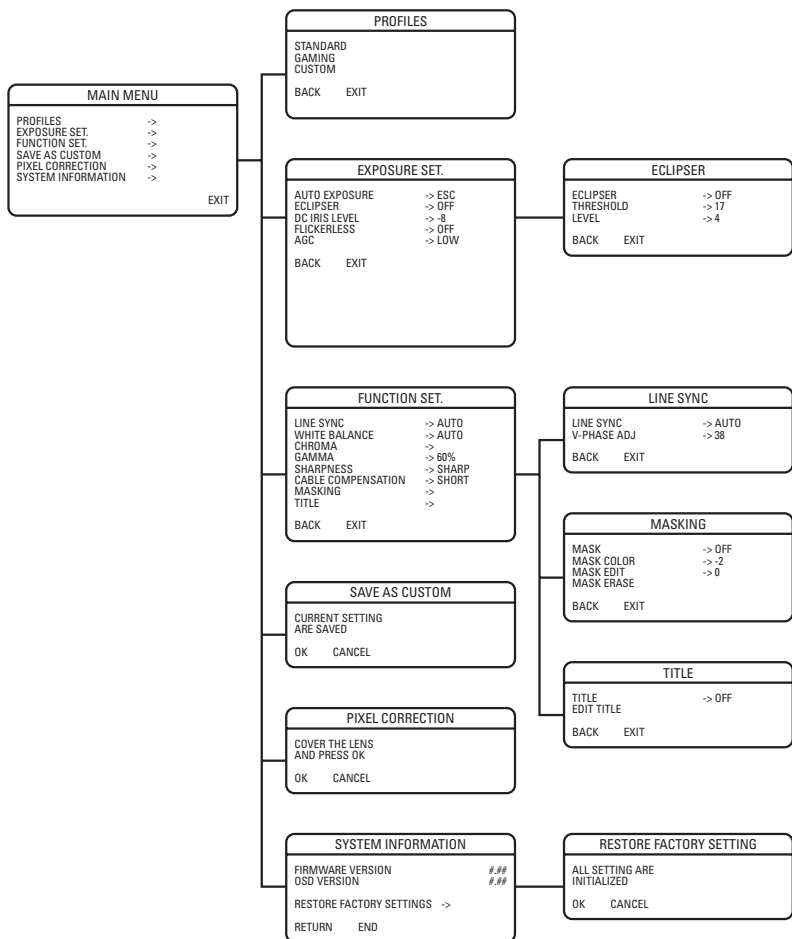

## ACCESSING THE SETUP MENUS

Use the five-position button controller on the side panel of the camera to access and navigate the on screen display (OSD) menus. Use the following table to navigate through the menu options.

Menu Options	Navigating the Menu
Display the MAIN MENU on the screen.	Press and hold down the center button for two seconds.
Move the cursor up or down in a menu; or toggle. through menu selections.	Move the button up or down.
Move the cursor right or left in a menu.	Move the button left or right.
Select menu or make a menu selection.	Press the center button.
Save a setting and then return to the menu.	Press the center button.

## LENS

The C10CH Series camera supports both manual and auto iris lenses, either fixed focal length or varifocal. It automatically senses an auto iris lens as soon as you plug in the connector.

The camera has a standard CS mount that can accept a C mount lens with a PCMA40 lens adapter.

To mount the lens onto the camera:

1. Make sure the lens will not touch the camera imager when installed.
2. Use clean, compressed air or a clean, dry lens cloth to make sure there is no dust or other foreign matter between the lens and the camera imager.
3. **C mount lens:** Screw the adapter onto the lens.
4. Screw the lens onto the lens mount.
5. **Auto iris lens:** Connect the 4-pin connector from the lens to the connector on the side of the camera.
6. Perform the lens focusing procedure before using the lens (refer to the *Lens Focusing* section of this guide).

## MOUNT

The C10CH Series camera can be mounted from either the top or bottom, depending on the type of camera mount used in your installation. Use a standard 1/4-20 screw. The maximum thread depth is 0.25 inches (6.4 mm).

## POWER

Connect 12 VDC or 24 VAC power to the back of the camera using the supplied terminal block. Use a Class 2 isolated power source for the C10CH camera that can supply 12 VDC  $\pm 15\%$  or 24 VAC  $\pm 15\%$ , 50/60 Hz. Maximum power consumption is approximately 3.5 watts.

## VIDEO

Connect a coaxial video cable to the BNC connector on the back of the camera.

## DC IRIS LEVEL ADJUSTMENT

Select this option to adjust the electronic properties of the DC drive auto iris lens to the auto iris electronic properties of the camera. Perform this procedure before using the camera or each time you change the lens.

To perform this procedure:

1. Focus the camera (refer to the *Lens Focus* section of this guide).
2. Aim the camera at a bright, flickerless scene.
3. Select DC IRIS LEVEL from the MAIN MENU.
4. Adjust the DC IRIS LEVEL value (for the best image). The range is -20 to 20. The default setting is -8.
5. Press the center of the button to save the value.
6. Exit the MAIN MENU.

## LENS FOCUS

After mounting the lens, you must focus your C10CH Series camera. Adjust both the back focus (on the camera) and the fine focus (on the lens).

**NOTE:** The back focus has already been adjusted using a standard CS mount lens. However, you might need to adjust it again to match the mounted lens.

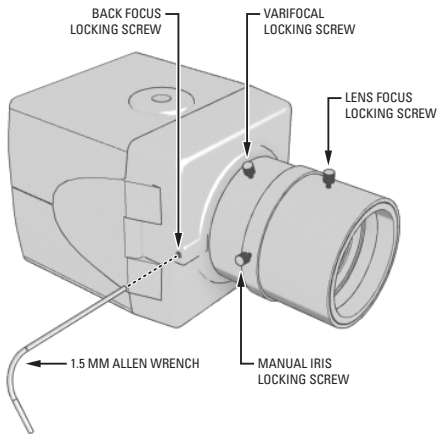

- Auto iris only:** Cover the auto iris lens with a suitable neutral density (ND) filter. This opens the iris completely. For best results, use an ND3 filter.
- Manual iris only:** Open the iris completely. The figure (right) shows the manual iris, varifocal, and lens focus locking screws for a sample lens. Refer to your lens documentation for more information.
- If automatic gain control (AGC) is set to OFF, set it to LOW or HIGH on the FUNCTION SETTINGS menu. AGC is set to LOW by default.
  - Display the FUNCTION SETTINGS menu.
  - Change AGC to either LOW or HIGH.
  - Select EXIT to save the AGC setting.
- Aim the camera at the farthest object in the field of view. Make sure it is at least 6.5 ft (2 m) away.
- Fixed focal length lens only:**
  - Set the lens focal length to far ( $\infty$ ).
  - Adjust the back focus:
    - Use a 1.5-mm Allen wrench to loosen the back focus locking screw.
    - Turn the lens until the image is focused.
    - Tighten the back focus locking screw clockwise.

**⚠ WARNING:** Do not overtighten the back focus locking screw because you may damage the camera.

(Back focus is a coarse adjustment. You will make the fine focus adjustment in the next step.)

  - Adjust the lens focus to achieve the best fine focus.

6. **Varifocal lens only:**

- a. Set the varifocal to wide (W) and the lens focal length to far ( $\infty$ ).
- b. Adjust the back focus:
  - (1) Use a 1.5-mm Allen wrench to loosen the back focus locking screw.
  - (2) Turn the lens until the image is focused.
  - (3) Tighten the back focus locking screw clockwise.



**WARNING:** Do not overtighten the back focus locking screw because you may damage the camera.

(Back focus is a coarse adjustment. You will make the fine focus adjustment in steps c and d.)

- c. Move the varifocal locking screw up or down to set the field of view.
  - d. Adjust the lens focus to achieve the best fine focus.
  - e. Repeat steps c and d until the focus is correct.
7. **Manual iris only:** Adjust the iris for the best picture quality. The largest aperture gives the best light sensitivity; the smallest aperture gives the greatest depth of field.
8. Tighten all lens locking screws.



**WARNING:** When tightening the lens locking screws, do not overtighten or force any screw.

9. **Auto iris only:** Remove the ND filter.
10. If necessary, reset the AGC setting to its previous value.
- a. Display the FUNCTION SETTINGS menu.
  - b. Change AGC to OFF, LOW, or HIGH.
  - c. Select EXIT to save the AGC setting.
11. **Auto iris only:** Perform the auto iris lens adjustment procedure (refer to the *DC Iris Level Adjustment* section of this guide).

## REVISION HISTORY

Manual #	Date	Comments
C2947M	11/07	Original version.
C2947M-A	1/08	Revised setup menus.
C2947M-B	3/08	Made references to manual numbers generic to simplify for future updates.

Pelco and the Pelco logo are registered trademarks of Pelco, Inc.

©Copyright 2008, Pelco, Inc. All rights reserved.

**Worldwide Headquarters** • 3500 Pelco Way • Clovis, California 93612 USA • [www.pelco.com](http://www.pelco.com)

USA & Canada • Tel: 800/289-9100 • Fax: 800/289-9150

International • Tel: 1-559/292-1981 • Fax: 1-559/348-1120